

Troubleshooting Lab 002:

This troubleshooting lab was designed to test some of your troubleshooting skills. This lab consists of approximately 14 faults divided up between 9 tickets (some tasks have multiple faults introduced). I have added Ticket 10 as an additional bonus task to build a new WiFi Network for the Enterprise in this lab. The tickets can be resolved in any order you choose. There are inter-dependencies between some of the Tickets.

Review the supplemental information included with this workbook (the next couple of pages), the lab topology in the simulator, the topologies provided throughout this document as well as the tickets to help zero in on the affected areas. There are no physical faults that have been introduced in this topology. Trust the diagrams.

Diagnose and fix the reported issues to the best of your ability. Once you believe you have resolved all of the faults within tickets 1-9, verify all of your work and then attempt to load up the simulated web server either by its hostname (<http://www.thenetworksdown.com>) or IP (<http://5.1.40.6>) using a web-browser from both Windows Workstations; WinPC1 and WinPC2.

Don't forget to save all of your configurations!

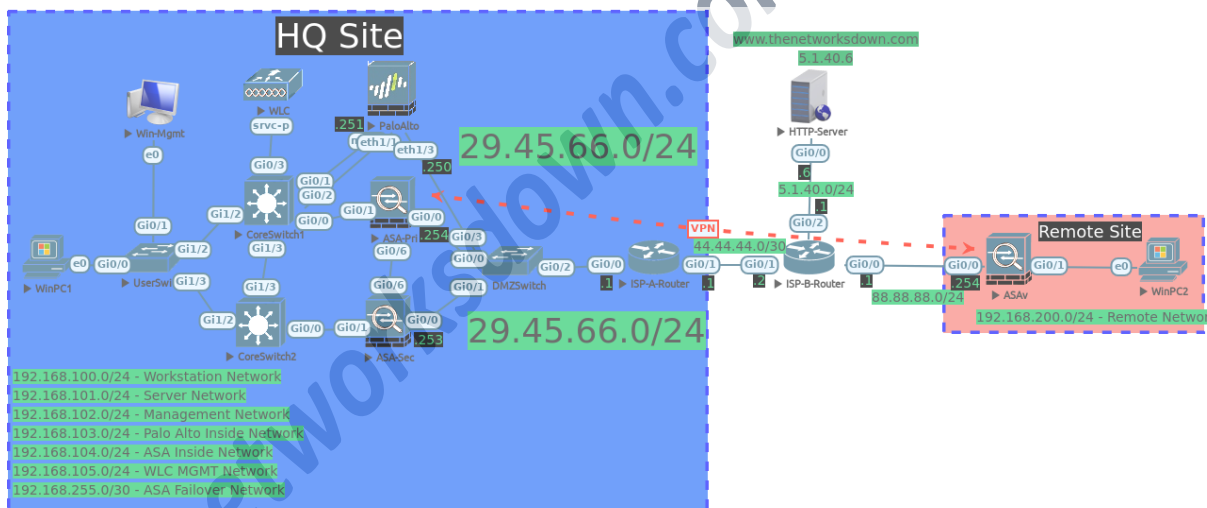

Disclaimer: All of the Public/Private IP space, Public/Private ASNs, Designs, Naming Schemes, Site Locations, Scenarios, etc. that are in use in this topology were selected at random. If any of the information in this lab overlaps with or resembles that of a production network, it is purely coincidental and is not intentional. <https://thenetworksdown.com>

The Network's Down – Troubleshooting LAB 002

Supplemental Information:

1. The “Service Provider Managed” nodes listed below have no faults introduced on them and you do not have Privileged EXEC access to them:
 - HTTP-Server
 - ISP-A-Router
 - ISP-B-Router
2. Below is a list of credentials for the Enterprise Managed nodes on this lab:

ASA Firewall Credentials

- Username: admin, Password: default1A
- There is no enable password configured on any of the ASAs
- Site to Site VPN IKEv1 Pre-Shared-Key: VPNKEY123
- ASA Failover Key: ASAF@IL

VTP Configuration

- Version: 2
- Domain: LABZ
- Password: labP@SS
- Server: CoreSwitch1
- Clients: CoreSwitch2, UserSwitch

Palo Alto Firewall Credentials

- Management IP Address: 192.168.102.151
- Username: admin
- Password: default1A

Virtual Wireless Controller Credentials

- Service IP Address: 192.168.102.150
- Username: admin
- Password: default1A

HTTP Server Credentials (to verify connectivity)

- Username: lab
- Password: lab

The Network's Down – Troubleshooting LAB 002

Supplemental IP Address Information:

- All SVI Interfaces on CoreSwitch1 are to end in .2
- All SVI Interfaces on CoreSwitch2 are to end in .3
- HQ Site IP Addressing:
 - o VLAN100 – Workstation Network – 192.168.100.0/24
 - o VLAN101 – Server Network – 192.168.101.0/24
 - o VLAN102 – Network Management Network – 192.168.102.0/24
 - o VLAN103 – Palo Alto Network – 192.168.103.0/24
 - o VLAN104 – ASA Inside Network – 192.168.104.0/24
 - o VLAN105 – WLC MGMT Network – 192.168.105.0/24
 - o ASA Failover Server Network – 192.168.255.0/30
 - o Site Public IP Addressing – 29.45.66.0/24
 - o Palo Alto PAT for all workstation traffic – 29.45.66.250
- Remote Site IP Addressing:
 - o Workstation Network – 192.168.200.0/24
 - o ASA Inside interface IP: 192.168.200.254/24
- Simulated Target Web Server IP Addressing:
 - o <http://www.thenetworksdown.com> or <http://5.1.40.6>
 - o **Note:** DNS *is not running nor has it been configured* in this lab. Feel free to build it out yourself or just connect by IP to verify connectivity as your. The end result is being able to reach the webpage from both the WinPC1 and WinPC2 nodes.

Overall Topology:

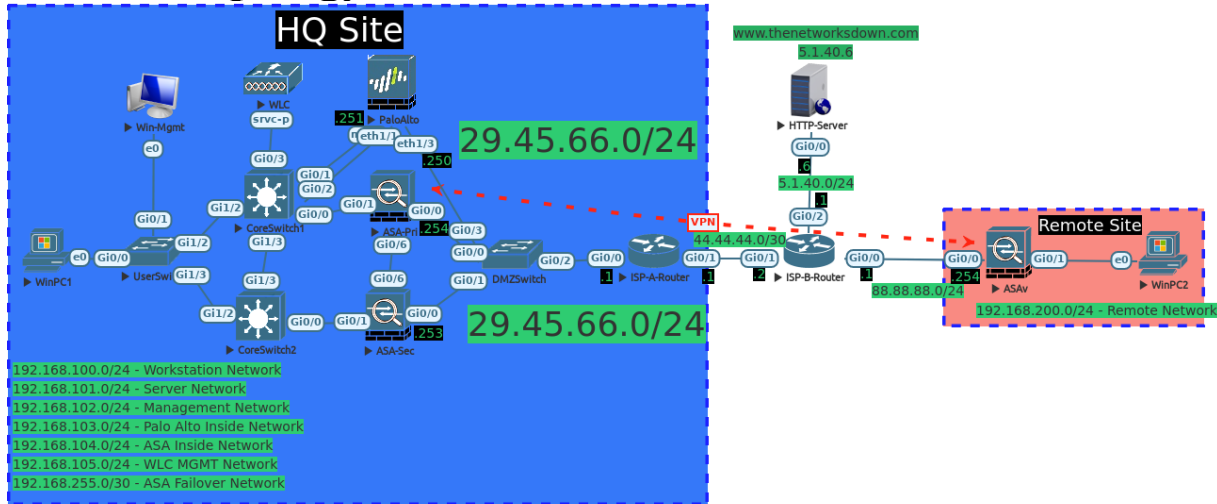

thenetworksdown.com P.

Troubleshooting Tickets:

Ticket 1: (VTP connectivity)

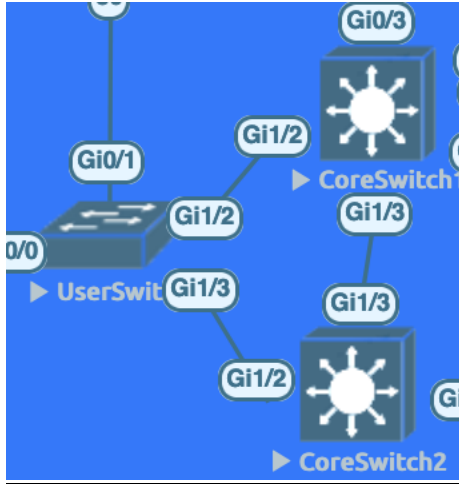

VTP updates are not being propagated between CoreSwitch1, CoreSwitch2 and UserSwitch. They should all be running VTP Version 2. Investigate and fix this issue.

Ticket 2: (Layer 2 connectivity)

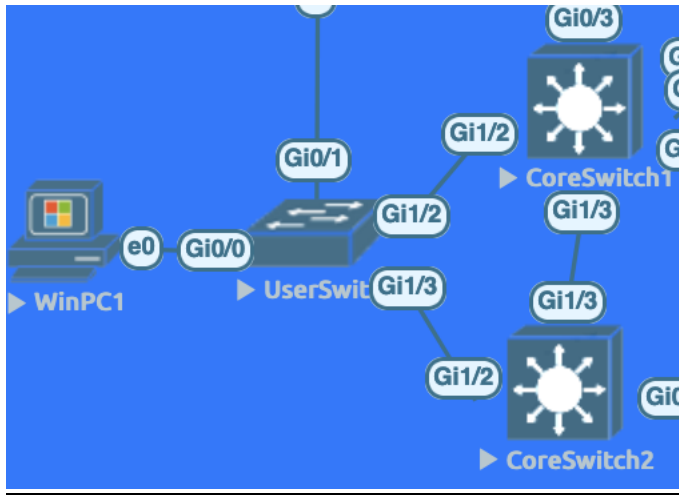

WinPC1 cannot ping its default gateway. There is no DHCP configured on this network, so you can assign an IP Address manually to WinPC1 from the PC VLAN. This issue will be resolved when you can ping 192.168.100.1, 192.168.100.2 and 192.168.100.3 from the WinPC1 computer.

Ticket 3: (ASA Failover)

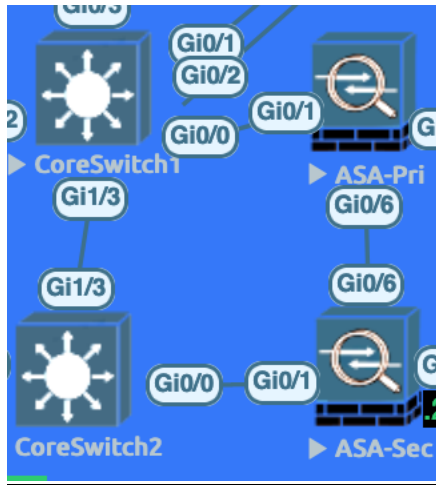

ASA-Sec was recently installed to become the standby ASA in the ASA VPN Pair at the HQ Site. Troubleshoot the configuration of ASA-Sec to allow it to function properly as the secondary firewall in the failover pair. ASA-Pri's failover configuration is correct. Do not change any of this config.

The Network's Down – Troubleshooting LAB 002

Ticket 4: (Site-to-Site VPN Connectivity)

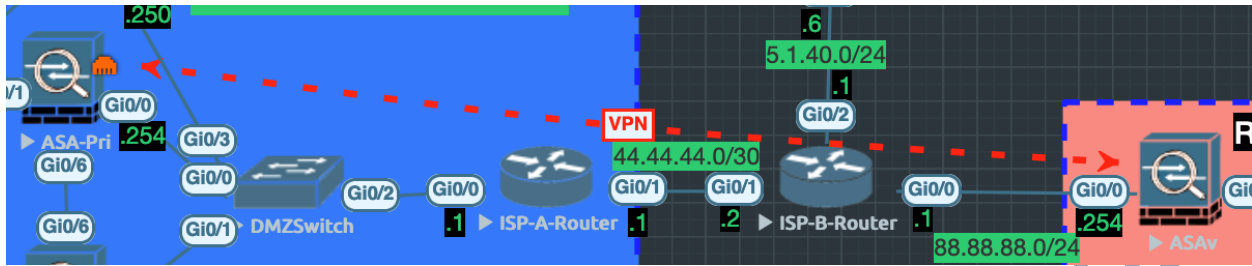

The Site-to-Site VPN between ASA-Pri at HQ and ASA at the Remote Site is not coming up. Diagnose and fix this issue.

Ticket 5: (EIGRP Connectivity)

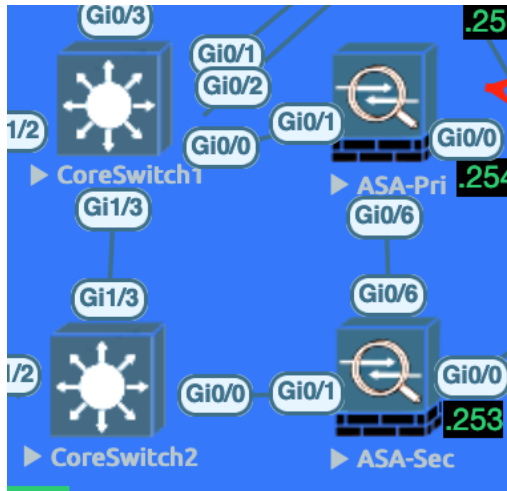

The EIGRP neighborship is not coming up between CoreSwitch1 and CoreSwitch2 on VLAN 102 or VLAN 104. Diagnose and resolve this connectivity issue.

Ticket 6: (DMZ Layer 2 connectivity)

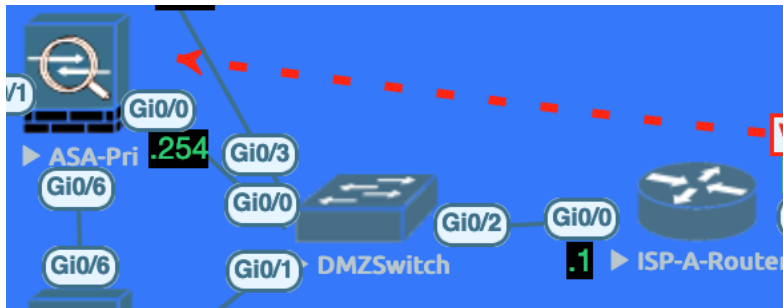

ISP-A has emailed you reporting that there is a connectivity issue between their router (ISP-A-Router) and your Firewall (ASA-Pri). Diagnose and resolve the connectivity issue.

The Network's Down – Troubleshooting LAB 002

Ticket 7: (First Hop Redundancy and Spanning Tree Optimization)

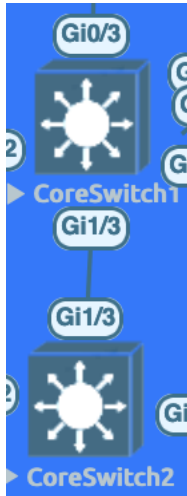

In an effort to help load balance traffic at the HQ Site on the core network, HSRP has been selected as the HQ Site's First Hop Redundancy Protocol. Confirm that HSRP is working properly between CoreSwitch1 and CoreSwitch2.

Ensure also that the following requirements have been met:

CoreSwitch2 should be configured as the Root Bridge for VLAN 105.

CoreSwitch1 should be configured as the backup Root Bridge for VLAN 105.

CoreSwitch2 should be configured as Active for HSRP Group 105.

CoreSwitch2 should be configured for HSRP Preemption for Groups 103 and 105.

Disclaimer: All of the Public/Private IP space, Public/Private ASNs, Designs, Naming Schemes, Site Locations, Scenarios, etc. that are in use in this topology were selected at random. If any of the information in this lab overlaps with or resembles that of a production network, it is purely coincidental and is not intentional. <https://thenetworksdown.com>

Ticket 8: *(Next-Generation Firewall Rule)*

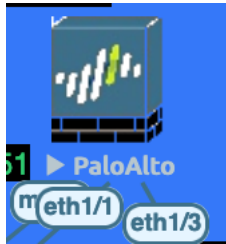

Traffic is not passing from the Internal Network to the Web Server (5.1.40.6). Investigate and correct this issue. Be as specific as possible when evaluating and resolving this connectivity issue.

Ticket 9: (OSPF Neighborship)

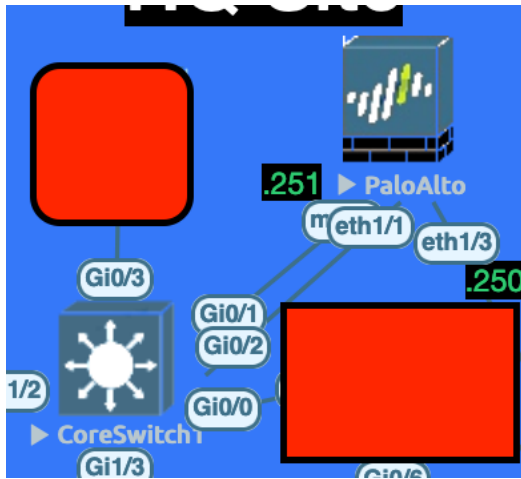

The OSPF neighbors are not coming up between CoreSwitch1 and the PaloAlto at the HQ Site. Diagnose and fix this issue.

Ticket 10: *WiFi Network Setup (Bonus)*

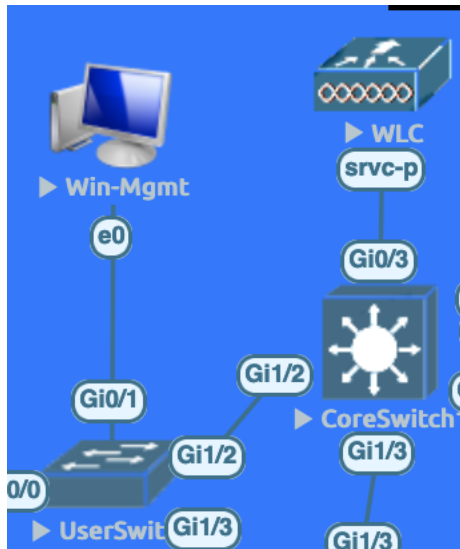

HQ has just purchased a new Virtual Wireless LAN Controller to setup a new WiFi Network. You have been tasked with building out a Lab Wireless Network for testing purposes. Using the Win-Mgmt PC, build a Wireless LAN called LAB-WLAN. Secure the LAB-WLAN network using WPA2 and the pre-shared-key of “secureLAB” (no quotes) using AES. Tie this WLAN to the management interface. Require DHCP address assignment for all clients on this WLAN. Enable Client Load Balancing and Client Band Selection.